

# DELI MASTER

Bakery oven

## DeliMaster 5



### UNIQUE BENEFITS



#### Multi Bake & Cook

Make your diners great reason to keep returning to your place. With DeliMaster ovens, you have the peace of mind that you will always achieve outstanding results. The prepared foods have a perfect colour, are juicy, crispy and healthy with a minimal fat content.



#### Deli Design

Simply keeps you baking with ease and comfort. Experience an excellent combination of features, exceptional ergonomics and attractive appearance. All this with a focus on safety, hygiene and long time reliability.



#### My Deli Controls

Gives you time to concentrate on baking and things that really matter to you. The simplest controls on the market will save you time and enable you to quickly and easily make all the necessary settings. Display response is perfect even with grease or gloved hands. Adapt the main menu to your needs.



#### Smart Investment

Generates money on savings for you every day. In-built heat exchanger, tripple glazed door glass, 50 mm thick thermoinsulation combined with low consumption automatic cleaning will ensure you great return on investment.

retigo® PERFECT BAKING AND MORE...

Láň 2310, PS 43, 756 64 Rožnov pod Radhoštěm, Tel. +420 571 665 511  
Fax: +420 571 665 554, sales@retigo.com, www.retigo.com

Certified by:



\* DVGW and WRAS certificates are valid for models with retractable hand shower only.

# FEATURES & BENEFITS

## Cooking

- **Hot air** 30 – 300 °C
- **Combination** 30 – 300 °C
- **Steaming** 30 – 130 °C
- **Inject and Pause** - Use Inject to quickly create the required amount of steam to be absorbed into the product during the Pause phase. This is the only way to ensure that the pastry is crispy on the surface and that the shade inside remains supple for a long time.
- **Over night cooking** – Saves time and money.
- **Rack timing** – Set individual rack times for multi product baking/ cooking.
- **AHC (Active Humidity Control)** – Automatic humidity control for great baking/cooking results.
- **Advanced steam generation system** – Two-step water preheating with in-built heat exchanger for perfect steam cooking results.
- **Crosswise racks** – Safer and comfortable GN handling. Better product visual control.
- **Regeneration/banqueting** – Bake/Cook, chill and regenerate to serve more diners in shorter times.
- **Delta T cooking** – Use advanced cooking method to reduce shrinkage on slow roasted meats getting amazing results.
- **Low temperature cooking** – Benefit from less weight loss, better taste.
- **Cook & Hold** – Let it cook and held serving temperature.
- **Golden Touch** – Add a golden-brown, crispy finish with just a touch.
- **Automatic preheating/cooling** minimises the loading temperature drop. Start baking/cooking with the desired temperature.
- **Sous-vide, Drying, Sterilization, Confit, Smoking** – Great way to make your menu special.

## My Vision Controls

- **8" display** – Perfect overview, easy and intuitive control.
- **My DeliControls** – Customize your menu so you have all you need right on the main screen.
- **Touch panel** – Panel works under all conditions and has a fast response, no mechanical elements, buttons or wheels.
- **Easy Baking** – Get great results even with less experienced chefs thanks to easy baking guidance.
- **6-point core probe** – Allows foods to be automatically cooked to any desired internal temperature.
- **Active Cleaning** – Low-cost automatic cleaning. No chef's time spent on cleaning any more.
- **1000 programs with 20 steps**
- **Pictograms** – Take a food picture on the main screen. Match it with a program. Touch it to get the desired baking/cooking results repeatedly.
- **Learn function** – All baking adjustments are recorded. At the end you save great results achieved and recall them again when needed.
- **Last 10** – Baking process easy to be used again by just a touch.
- **Multitasking** – Unique opportunity to work with a display during baking.
- **Automatic start** – The ability to schedule a delayed start.
- **EcoLogic** – Energy consumption shown right on the screen. Keeps your cost under control.
- **Continuous cooking time option** - Saves your time during busy operations.

## Other equipment

- **Triple glazed door glass** - Advanced energy savings and external glass that does not burn you.
- **Active Cleaning** – Low-cost automatic cleaning. No chef's time spent on cleaning any more.
- **Auto-reversing fan** – Excellent evenness to deliver high product color and texture uniformity.
- **Flap valve** – Patented dehumidification system for great colour and crispiness.
- **7 Fan speeds** – Precise control of air distribution for desired results with different products.
- **Automatic Fan stop** – No scalding when the door opened quickly.
- **Fan timing** – 3 steps for greater evenness and gentle cooking.
- **Massive door handle** – Comfortable and safe handling with silver ion material contain for bacteria reduction.
- **AISI 304 stainless steel** – Exceptional quality with a special coating for an extended life time.
- **Hygienic cooking chamber with round inner corners** – Trouble free maintenance.
- **Retractable hand shower** – External water supply hose with spray nozzle. Extra water source at your disposal.
- **Run-off tray under the door** – No slipping on wet floor.
- **Two water inlets** – Saves a water treatment unit's capacity.
- **WSS (Water Saving System)** – Special drain system & in-built heat exchanger to save water related cost.
- **Removable GN holders** with 80 mm spacing

## Connectivity

- **USB plug-in** – Transfer useful data easily to and from the oven.
- **Ethernet/LAN** – Allows remote access for data management.
- **VisionCombi software** – Program and pictogram management in your PC, HACCP data view.

## Operation logs

- **HACCP records** – Easy and immediate analysis of critical baking points.
- **Complete operating records**

## Service

- **SDS (Service Diagnostic System)** – Easy unit check up and trouble shooting.

## Unit options

- Left door
- Safety door opening in two steps
- Connection to the system for power consumption optimization

## Optional accessories

DELI PROOFER  
ST-DM 5 stand with capacity 16 x GN 600/400  
ST-DM 5 CS stand with capacity 14 x GN 600/400 with wheels  
VISION VENT condensation hood  
GN ADAPTER for 1 x GN1/1  
VISION OIL GUN  
VISION SMOKER  
ACCESSORIES – Gastro containers, cleaning agents, water treatments

## TECHNICAL DATA

Model	DM 5
Heat source	Electricity
Steam generator	Injection
Capacity	5 x 600/400
Baking space	1,2 m <sup>2</sup>
Spacing	80 mm
Dimensions (w x h x d)	933 x 786 x 821 mm
Weight	116 kg
Total power	10,9 kW
Heat power	10,3 kW
Fuse	16 A
Voltage	3N~/380-415V/50-60 Hz
Noise level	max. 70 dBA
Water/Drain connection	G 3/4" / 50 mm
Temperature	30 – 300 °C

### STACKING OPTIONS

Lower unit	Upper unit
DM 5	DM 5
DM 8	DM 5
DeliProofer	DM 5

### OPTIONAL VOLTAGE

1N~(2~)/220-240V/50-60 Hz
3~/200-208V/50-60Hz
3~/220-240V/50-60Hz
3~/400V/50-60Hz
3~/440-480V/50-60Hz

# DRAWINGS

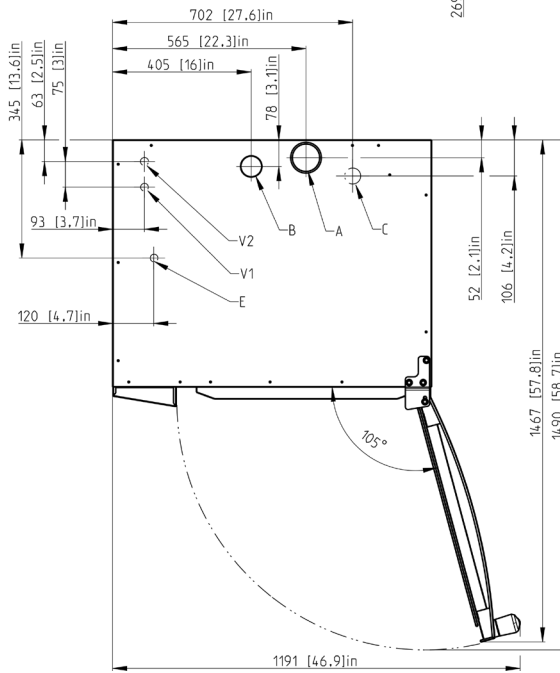
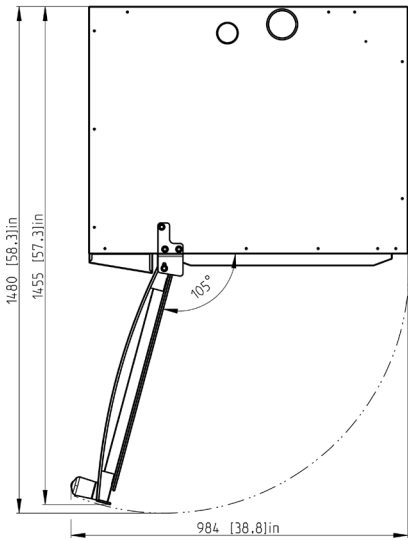
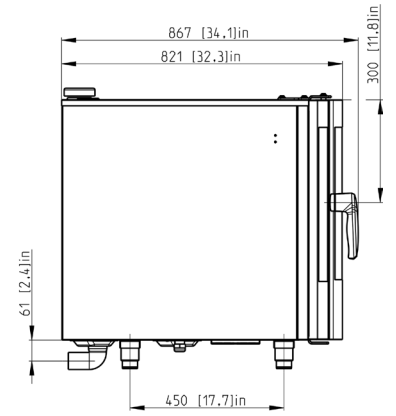
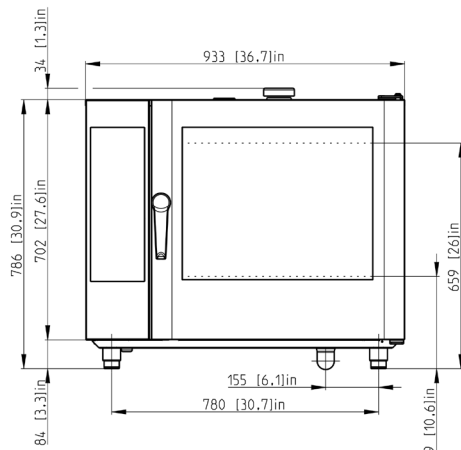
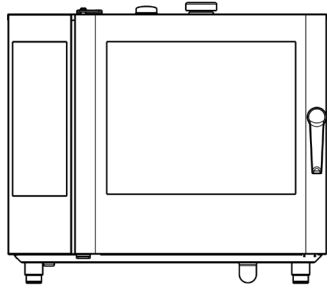

A	flap valve
B	chimney
C	waste
E	electricity
V1	untreated water
V2	treated water